

# The world's coolest, quietest and most energy efficient evaporative air conditioning



**AUSTRALIAN  
DESIGNED, MADE  
AND OWNED**

*“Seeley International never stops striving to innovate and build the world’s most energy efficient heaters and air conditioners.*

*It is this commitment to excellence that’s at the heart of everything we do.”*

Frank Seeley AM, DUniv Flin, FAICD  
Founder and Executive Chairman



## PEACE OF MIND WITH OUR SPECIALIST DEALER NETWORK

Members^ of Climate Masters of Seeley International are heating and cooling experts, and provide a level of premium service you won’t get anywhere else.

^Members are independent retailers.



**UNSURPASSED  
PROFESSIONALISM  
AND EXPERTISE**



**UNRIVALED  
QUALITY SERVICE**



**AFTER CARE THAT  
REALLY DELIVERS**



**RELIABILITY**



**EXCLUSIVE  
SUPERNOVA™  
RANGE**

## THE AWARD WINNING COMPANY

Seeley International consistently wins awards each year for new product design, innovation and the environment. Recent awards include:



melbourne  
design  
awards



sydney  
design  
awards



# UP TO 80% CHEAPER TO RUN THAN DUCTED REVERSE CYCLE AIR CONDITIONING\*



NEW!

## Introducing the Black Magic™ MINI-CELL<sup>^</sup> CHILLCEL® Pads

Our revolutionary **Black Magic™ Mini-Cell<sup>^</sup> Chillcel® pads** have transformed the aesthetics of our coolers as they seamlessly blend into their surroundings; maintaining our global leading Mini-cell<sup>^</sup> Chillcel® pad technology, which increases surface area of the pads by 25%, dramatically multiplying cooling capacity and efficiency - **BEYOND BELIEF!**

<sup>^</sup>Patent pending.



### LOWEST RUNNING COST IN AUSTRALIA

Cool your whole home from the cost of running a single light globe



### AUSTRALIAN MADE

Built in Australia to withstand the harshest climates



### QUIET TO RUN

Ask your dealer for a demonstration – see if you can hear how quiet it is



### BUILT TO LAST

Quality that lasts – 7 year comprehensive warranty\*\*



### LOW MAINTENANCE

Innovative design for minimal long term cost



### FRESH, COOL CLEAN AIR

Delivers fresh, outside air – not stale recycled air



### TECHNOLOGY THAT PUTS YOU IN CONTROL

Available with the touch screen MagIQtouch® controller



### LIFESTYLE

Perfect for alfresco living, with options for security vents for when you're out and about.



### NATA TESTING

NATA accredited test results substantiate superior product performance.

# UP TO 80% CHEAPER TO RUN

**Breezair is the world's first inverter evaporative air conditioner and that means lower energy usage and running costs.**

With energy prices escalating, evaporative air conditioning has a significant edge on reverse cycle, when it comes to energy efficiency, performance and easy living.



## LOWEST RUNNING COST IN AUSTRALIA

Up to 80% cheaper to run than ducted reverse cycle air conditioning\*



## ENERGY EFFICIENT

Better for your pocket and for the environment

## RUNNING COST PER YEAR\*

**Savings of up to \$250 per year!**

When compared to reverse cycle

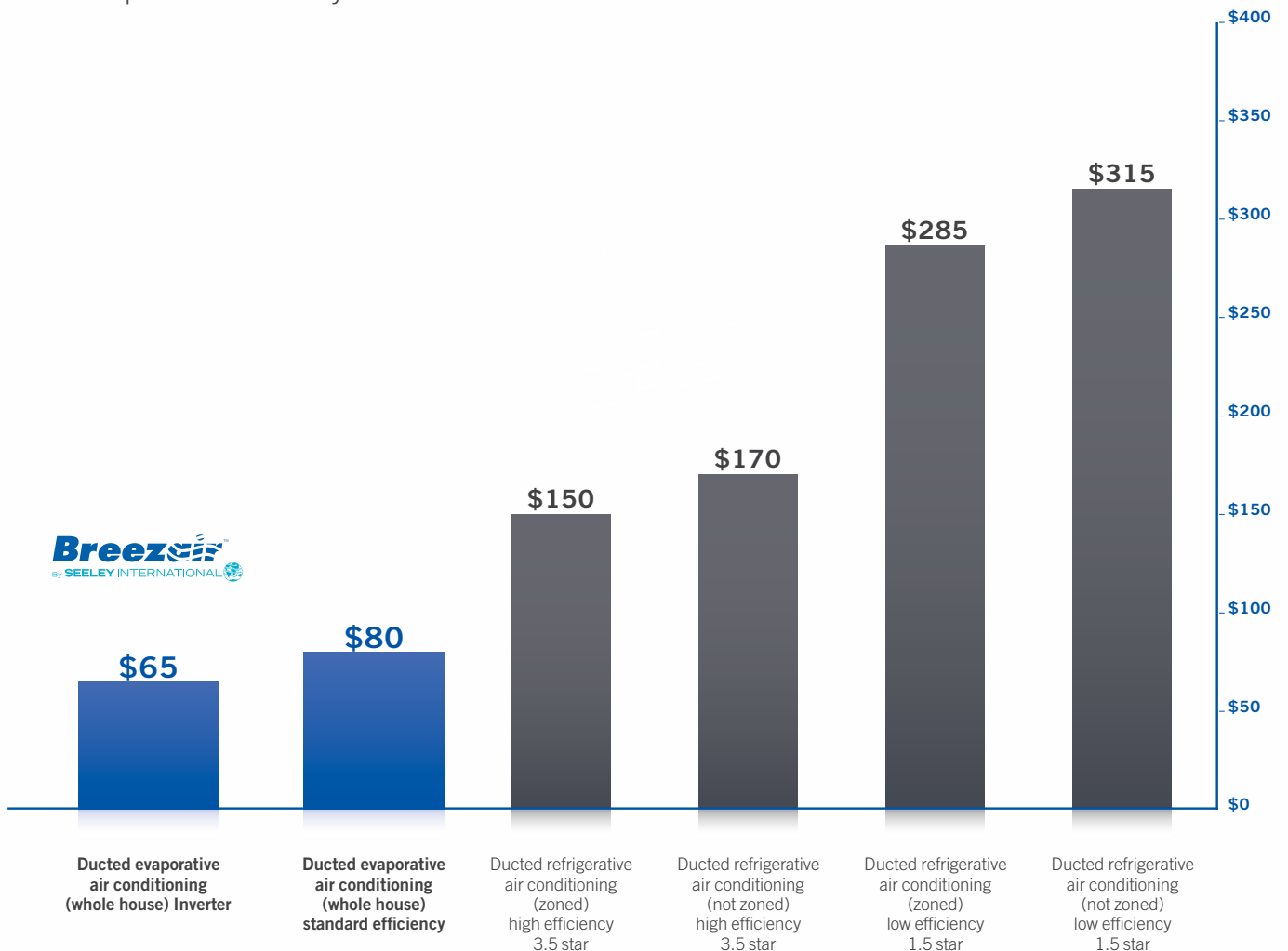

\*Based on approximate running costs figures from publicly sourced data. Comparison with 2 star not zoned ducted refrigerative system in a large size (220m<sup>2</sup>) 2-star pre 2005 house in a Melbourne climate, cooling all day on the weekend and in the morning and evenings when internal temperatures are high.

# BETTER FOR THE ENVIRONMENT

Every time a customer chooses a Breezair evaporative air conditioner over a refrigerated system, the benefits for the environment are significant.

The power consumption of just one ducted refrigerated air conditioner can result in up to 1.4 tonnes of harmful CO<sub>2</sub> being pumped into the atmosphere each year. On the other hand, Breezair evaporative air conditioners are so efficient, they produce less than one tenth of this volume.\*\*

By choosing Breezair, you can help reduce the amount of harmful greenhouse emissions entering our environment.

## CO<sub>2</sub> EMISSIONS (KG/YR)

CO<sub>2</sub> savings equivalent to planting 16 gum trees\*\*

When compared to reverse cycle



### REDUCED GREENHOUSE GAS EMISSIONS

Up to 80% less CO<sub>2</sub> emissions than ducted reverse cycle\*



### MINIMAL WATER USAGE

Breezair evaporative air conditioning uses up to 83% less water over summer than a shower^



### RESPONSIBLE USE OF RENEWABLE RESOURCES

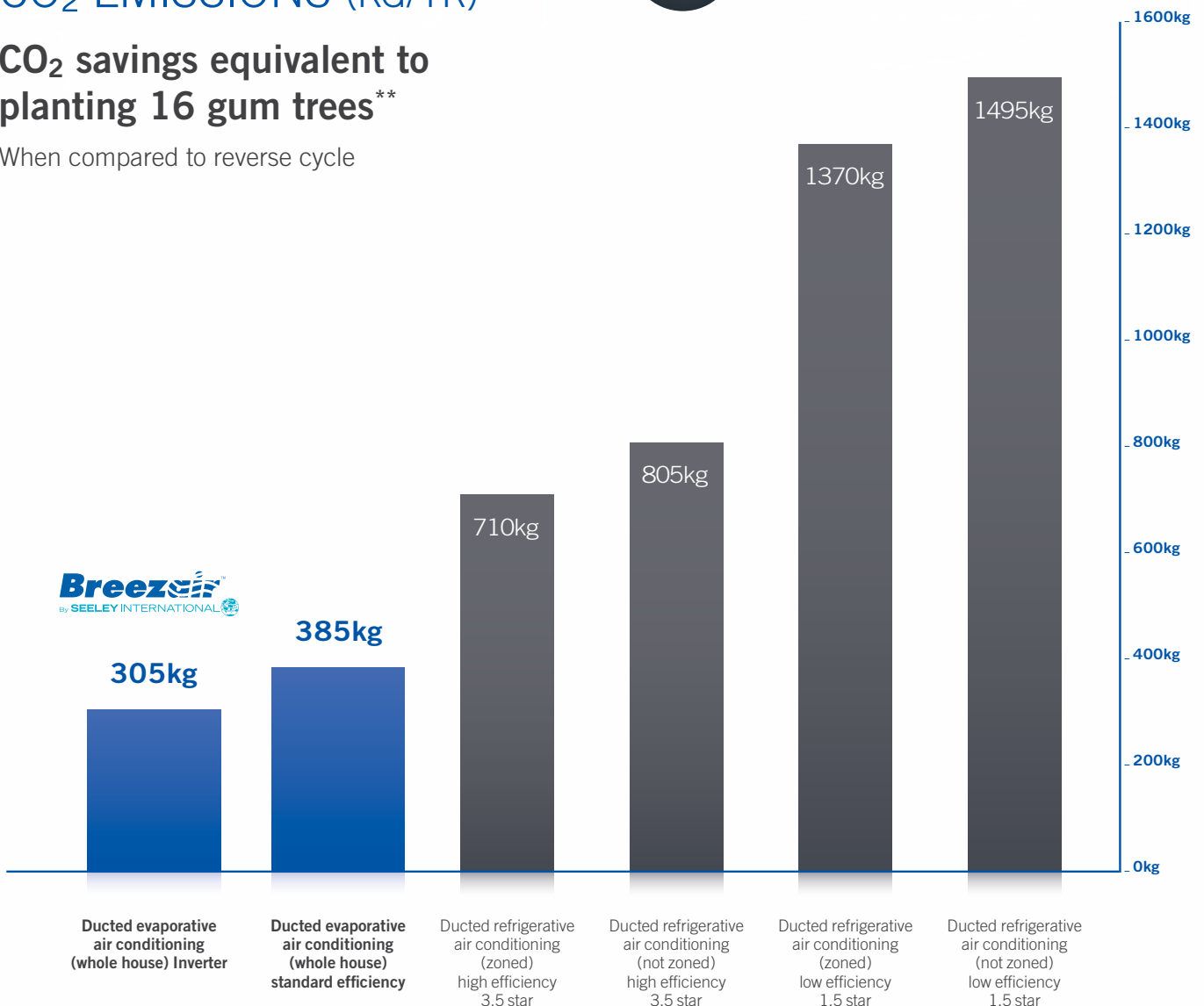

\*Seeley International's calculation based on approximate running costs figures from publically sourced data. Comparison with 2 star not zoned ducted refrigerative system in a large size (220m<sup>2</sup>) 2-star pre 2005 house in a Melbourne climate, cooling all day on the weekend and in the morning and evenings when internal temperatures are high.  
 \*\*This is an estimate based on the CO<sub>2</sub> calculation above and using the data from forestlearning.edu.au, 'Carbon and its storage in forest and wood products' article, published 2011. Calculation based on a spotted gum tree that sequesters 72kg CO<sub>2</sub>/YR.  
 ^Water use calculations for shower are based on shower water use for 4 people, 10 mins per person per day at 9L/min, over three months, calculated at 32,400 L. Water use calculations for Braemar evaporative air conditioning over three months are 5,405 L.

# MAGIQTOUCH® CONTROLLER

## TOUCH SCREEN TECHNOLOGY

Smart, sophisticated and incredibly intuitive, your MagIQtouch® controller makes operating your Breezair, a breeze. Control the temperature, fan speed and many more features on a user friendly touch screen. Discreet and modern design will blend seamlessly into the décor of your home.

### MAGIQTOUCH® controller



Can be Wi-Fi enabled for use with our smart app and smart home integration^

### MAGIQTOUCH® Radio Frequency controller



Use the latest in Radio Frequency (RF) channel hopping technology with no need for wiring

## MAIN FEATURES



### PROGRAM MODE

Programmable 7 day, 4 time period program, customisable to suit your lifestyle (including a temporary over-ride function).



### USEFUL SETTINGS

Access features such as child lock, quiet mode and servicing information.



### AUTO-CLEAN™ FUNCTION

World's first fully automated pad cleansing capability enables you to set and forget ensuring your cooling pads remain clean, fresh and functional all summer long, season after season.\*



## OPTIONAL EXTRA

### MAGIQTOUCH® AIR SENSOR

MagIQtouch® Air Sensor monitors temperature and humidity levels. It allows you to mount your MagIQtouch® controller in the most convenient place in your home, as the MagIQtouch® Air Sensor will then take over temperature control from the MagIQtouch® controller. This can then be located in the best place in the house to ensure ultimate cooling comfort for everyone.

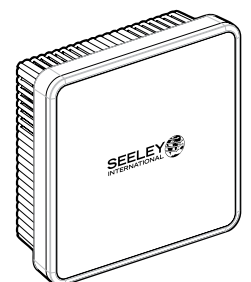

\*Only for cooler models fitted with the water management system. Ask your dealer for further information.

# MAGI@TOUCH®

## Wi-Fi SMART APP\*



Control your cooling comfort needs directly from your mobile device! For example, turn on your cooler wherever you are, ensuring you come home to a cool home on those hot summer days.

The smart app is free and available for download on your smartphone.

## SMART HOME INTEGRATION\*



Control temperature and fan speeds with your voice through Amazon<sup>#</sup> Alexa and your Google Assistant<sup>^</sup> technologies. Voice commands are easy and simple to use, like “Alexa, turn on my Cooler” or “Hey Google, set the Cooler to 21 degrees”.



Available for download now on iOS and Android



Google Home



amazon echo

## EXCLUSIVE TO CMSI EXTERNAL AIR SENSOR\*\*

- Displays current outside temperature
- Intuitively optimises water and energy usage based on outside ambient conditions
- Extends the life of your air conditioner by automatically draining the water tank when temperature nears freezing



\*Requires Magi@Touch® wall control, Magi@Touch® Wi-Fi smart kit and Magi@Touch® account to operate.

<sup>^</sup>Requires Wi-Fi, Google Account and a compatible device. Google and Google Home are trademarks of Google LLC.

<sup>#</sup>Requires Wi-Fi, Amazon Account and a compatible device.

\*\*Only available on Breezair EXS models.

# BREEZAIR DUCTED EVAPORATIVE AIR

## FEATURES AND BENEFITS

### HIGHLY DURABLE AND NON-CORROSIVE OUTER CASING

- High performance Permatuf® polymer construction will not corrode or rust

### ICON® SERIES FAN IS ULTRA-QUIET

- Designed to deliver optimum air output at all times
- Ultra-quiet centrifugal fan with 10 speeds
- Use “Fan Only” mode (no water) to blow fresh air through the home and expel odours

### HUSHPOWER® DIRECT DRIVE INVERTACOOOL MOTOR USES LESS ENERGY

- Exclusive to Breezair and manufactured in Australia
- Incredibly quiet and efficient throughout operating range
- Unsurpassed reliability
- Corrosion proofed throughout with parts that won't rust

### POWER CONTROL MODULE HELPS SAVE WATER AND POWER

- Advanced electronics ensure maximum efficiency
- Microprocessor constantly analyses water quality, water consumption and power output
- Incredibly smart, exceptionally reliable and durable

### TORNADO® PUMP THAT WON'T BLOCK

- Australian designed and manufactured
- Exceptional reliability in extreme conditions
- Dual directional – it can't block!

## OPTIONAL EXTRA FIREWALL EMBER SCREEN

- Helps guard against ember attack in bushfires
- Made from non-combustible mesh
- Maximum aperture of 2mm
- Can be fitted to existing cooler pad frames
- Minimal reduction in air flow of 5%
- To meet the BAL rating, the cooler also requires a firewall auto seal installed
- Fitting both amber screen and auto seal to comply with BAL will reduce airflow by up to 15%



# R CONDITIONING

## DRAIN AND CLEAN FUNCTION

- Automatic water draining when the system is not in use avoids ongoing algae growth

Only available with selected MagIQtouch® controller models. Regular maintenance (typically every 2 years for domestic use) is still required.

## Breakthrough Black Magic™ MINI-CELL^ CHILLCEL® pad technology

- The only evaporative cooling medium of its kind. Fully manufactured in Australia to address the harsh Australian climate. It's an **absolute out-performer!**
- Exclusive small cell design provides cutting-edge cooling capacity.
- Maintains our global leading Mini-Cell^ Chillcel® pad technology, which increases surface area of the pads by 25%, dramatically multiplying cooling capacity and efficiency - **BEYOND BELIEF!**
- **BLACK MAGIC™ MINI-CELL^ CHILLCEL® pads** deliver transformational aesthetics to your home enabling the unit to blend seamlessly into its surroundings.

^Patent pending

## EXCEPTIONAL WATER DISTRIBUTION INCREASES COOLING EFFECT

- Unique to Breezair, this Australian design ensures constant, even pad saturation increasing the cooling effect and outperforming competitor products



## WATERMISER® SAVES WATER

- Uses the minimum amount of water to achieve high efficiency cooling
- Water quality monitoring to maximise water savings
- Leak detection when the unit is in use

## WEATHERSEAL® REDUCES DRAUGHTS AND DUST

- Automatic sealing system
- Reduces need for winter cover

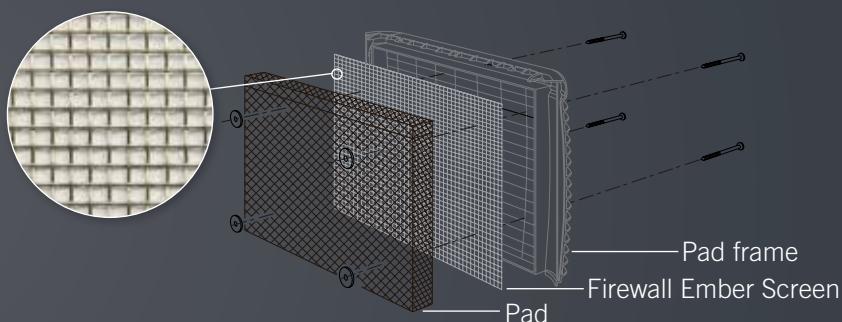

# BREEZAIR DUCTED EVAPORATIVE AIR



## SUPERCOOL

Enjoy superior cooling with Breezair Supercool

This premium range has extra thick Chillcel pads, producing up to 13% more cooling when compared to the Icon range. Breezair Supercool is only available from your Climate Masters of Seeley International specialist.

	EXS160	EXS180	EXS200	EXS220
<b>Cooling capacity (kW)</b>	<b>11.4</b>	<b>13.1</b>	<b>14.3</b>	<b>15.1</b>
Nominal power motor (W)	550	750	1100	1500
Width (mm)	1160	1160	1160	1160
Depth (mm)	1160	1160	1160	1160
Height (mm)	860	860	860	860
Operating weight (kg)	94	94	94	94
Airflow (L/sec)	1720	2060	2320	2540



## ICON

The Breezair Icon range is a proven high performer, cooling your whole home and saving you on energy costs.

	EXQ150	EXQ170	EXQ190	EXQ210
<b>Cooling capacity (kW)</b>	<b>10.8</b>	<b>11.6</b>	<b>13.8</b>	<b>14.5</b>
Nominal power motor (w)	550	750	1100	1500
Width (mm)	1160	1160	1160	1160
Depth (mm)	1160	1160	1160	1160
Height (mm)	860	860	860	860
Operating weight (kg)	90	90	90	91
Airflow (L/sec)	1720	2070	2290	2540

The above data was drawn from Meridian Test Laboratory's test analysis. The testing was performed by a NATA accredited laboratory to the requirements of the Australian standard AS2913-2000 "Evaporative Air Conditioning Equipment." Achievable with ambient 38 °C DB, 21 °C WB, room temperature 27.4 °C.

# R CONDITIONING RANGE

## AVAILABLE COLOURS\*



SLATE GREY



TERRACOTTA



BEIGE



HERITAGE GREEN

\* Colours may vary. Heritage Green made to order.

## KEEP YOUR HOME SECURE

### Did you know you can cool your home when you're out and about without leaving your doors and windows open?

Ask your dealer about installing a cost effective and easy to install **Security Relief Vent** in your home, allowing you to run your evaporative air conditioner while you are out, with all your windows and doors safely closed and locked.

When you return home, simply open up your windows and doors as normal, maintaining the fresh cool air throughout your home and open living areas.



## LOOKING FOR A COMBINED COOLING AND HEATING SOLUTION?

Seeley International's range of products also includes ducted gas heating that complements your evaporative air conditioning system. Take advantage of controlling your cooling and heating systems from the same controller – the innovative touch screen MagIQtouch® Controller.

Ask your dealer for the right solution for your home.

Introducing...

**Breezair**<sup>TM</sup>  
By SEELEY INTERNATIONAL 

# Extraordinary Air<sup>TM</sup>

EVAPORATIVE AIR CONDITIONING

Never settle for ordinary!<sup>TM</sup>



*Architecturally designed.*  
**The coolest ever evaporative air conditioner.**

**AUSTRALIAN  
DESIGNED, MADE  
AND OWNED**





## EXTRAORDINAIRE

Enjoy superior cooling with **Breezair Extraordinaire™**

Breezair is Seeley International's premium, world-leading evaporative air conditioner brand, and the new Breezair Extraordinaire™ has redefined the future for whole-of-home cooling.

**Comprehensive range covering all residential cooling requirements.**

	XTR2000	XTR3000	XTR4000	XTR5000
<b>Cooling capacity (kW)</b>	<b>9.8</b>	<b>12.4</b>	<b>14.5</b>	<b>17.4</b>
Nominal power motor (W)	340	430	600	950
Width (mm)	1160	1160	1160	1160
Depth (mm)	1400	1400	1400	1400
Height Front (mm)	840	840	840	840
Height Rear (mm)	550	550	550	550
Operating weight (kg)	86	86	86	86
Airflow (L/sec)	1600	2100	2480	2900

## AVAILABLE COLOURS

**Make a statement by standing out or blending in.**

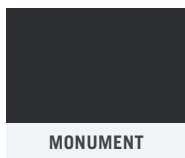

\*Colours may vary. Heritage Green made to order.

**Hugging every roof angle from 10 to 40 degrees and increasing invisibility from the street.**

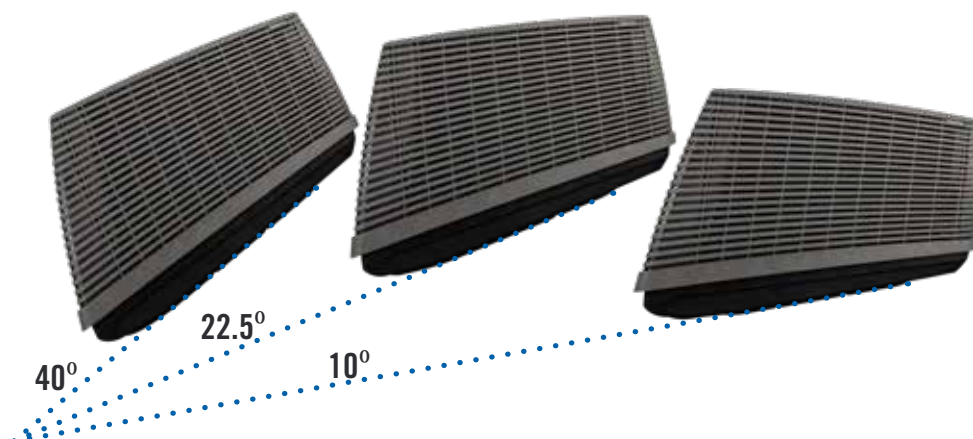

*Where's the cooler?!*

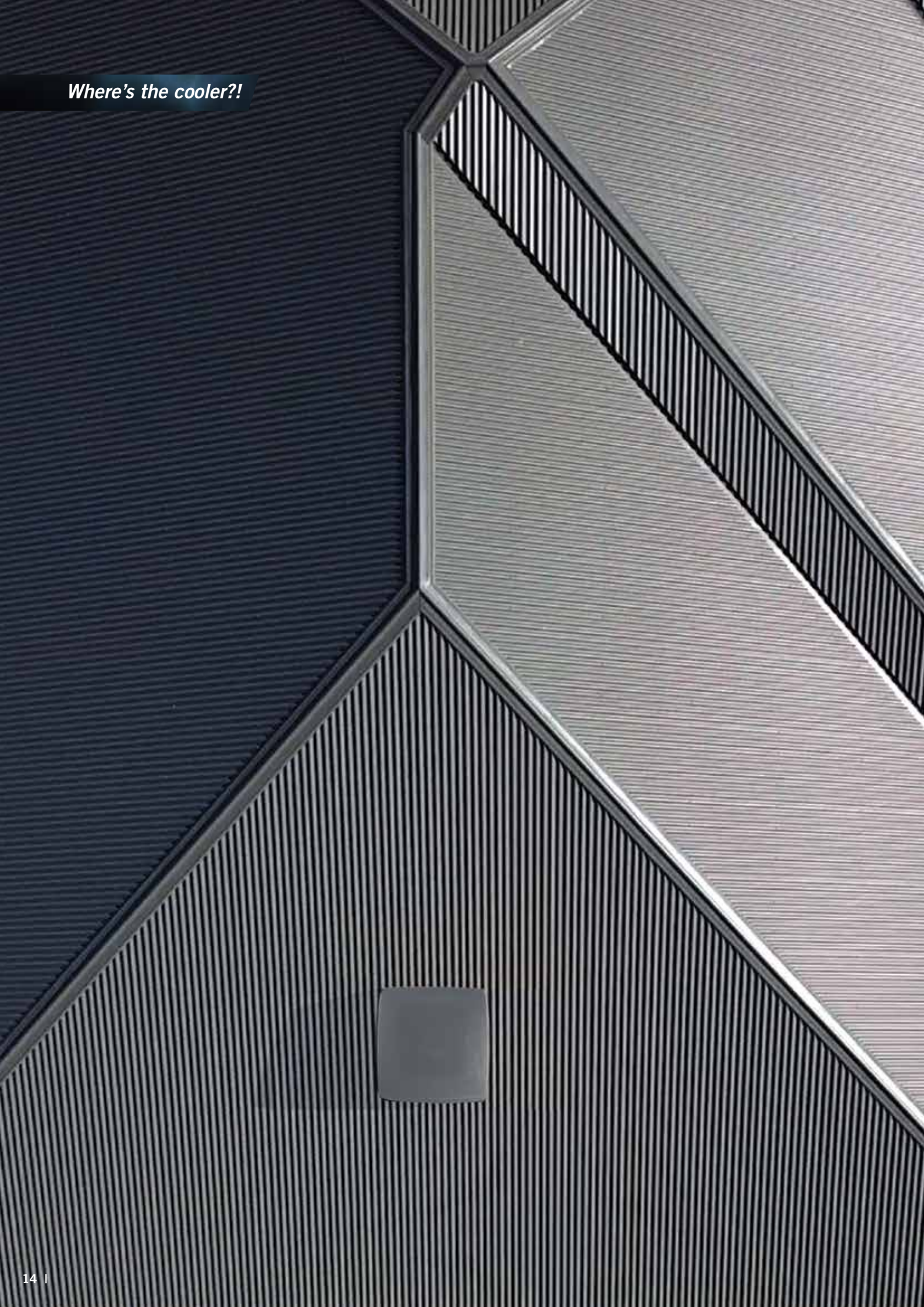

# COMPREHENSIVE WARRANTY

For complete peace of mind, Breezair backs every one of its air conditioning systems with an industry leading comprehensive warranty program.

This includes a 7 year warranty\* (with a compulsory chargeable service in the fourth year), 10 year cover on all structural components, plus a hefty 25 year cover against corrosion, on its Permatuf® cabinets.

Please refer to your home owner's manual for all service and warranty terms and conditions.



## REGISTER YOUR WARRANTY AND GO INTO THE DRAW TO WIN \$500 WORTH OF PRIZES\*\*

**Prize includes 2 free services (up to the value of \$400) and a \$100 eftpos gift card**

All you need is your home owners' manual.

Visit [seeleyinternational.com/warranty](http://seeleyinternational.com/warranty) and follow the prompts.

Have your serial number ready.

\*\*Terms and conditions apply. See [seeleyinternational.com](http://seeleyinternational.com) for more information, including the dates of the promotion.



## BREEZAIR NATIONAL SERVICE NETWORK

Seeley International has an established network of highly professional dealers and service agents throughout Australia. To book a service visit [seeleyinternational.com/service](http://seeleyinternational.com/service) or call 1300 650 444.

\*The 7 year comprehensive warranty is available exclusively (i.e. only) from Seeley International participating dealers. The warranty has terms and conditions, including the requirement for servicing of the product in accordance with the owner's manual. In the fourth year the service must be performed by Seeley International or its appointed nominee.

# SEELEY INTERNATIONAL



## BREEZAIR

Ducted Evaporative Air Conditioning

## BRAEMAR

Ducted Evaporative Air Conditioning | Ducted Gas Heating  
Reverse Cycle Air Conditioning | Gas Wall Furnaces and Space Heaters

## CLIMATE WIZARD

Indirect Evaporative Air Conditioning

## CONVAIR

Portable Air Conditioning

## COOLAIR

Ducted Evaporative Air Conditioning

## COOLERADO

Indirect Evaporative Air Conditioning

## AIRA

Direct and Indirect Evaporative Air Conditioning | Ducted Gas Heating  
Commercial Gas Space Heating | Energy Recovery Systems

## INTEGRATED COMFORT INCORPORATED (ICI)

Dual Cool® Patented Dual Evaporative pre-cooling products

[seeleyinternational.com/breezair](http://seeleyinternational.com/breezair)

1300 360 815



With the generous support of our Australasian dealers we are proud to be the National Variety Bash partner supporting kids in need across Australia.

Seeley International Pty Ltd  
ABN 23 054 687 035

112 O'Sullivan Beach Road, Lonsdale, SA 5160  
Phone: (08) 8328 3850 Fax: (08) 8328 3950

Email: [enquiries@seeleyinternational.com](mailto:enquiries@seeleyinternational.com)  
[seeleyinternational.com](http://seeleyinternational.com)

Information in this brochure was correct at the time of preparation. E & OE

Cat No CMSI001 REV I (0819)

